



# Biochemical Diagnostics, Inc.

## The Multi-Prep® Sample Preparation/Evaporation Workstation Operation Manual

### TABLE OF CONTENTS

- I. INTRODUCTION
- II. SPECIFICATIONS
- III. OPERATING INSTRUCTIONS
- IV. INITIAL INSPECTION AND SETUP
  - A. INITIAL INSPECTION
  - B. ASSEMBLY
- V. INSTRUMENT TURN ON AND SETUP
  - A. POWER SWITCH
  - B. TEMPERATURE CONTROL
  - C. CALIBRATION
  - D. POWER RESET
- VI. MAINTENANCE
- VII. PRECAUTIONS
- VIII. WARRANTY
- IX. WIRING DIAGRAM

## I. INTRODUCTION

Biochemical Diagnostics Multi-Prep® Sample preparation/Evaporation (SP/E) Workstation is a laboratory instrument designed to make your SPE sample preparation faster, more efficient, and less subject to operator error. This is accomplished by using a single workstation to house the sample collection tubes during the elution, sample evaporation and derivatization operations. By eliminating the transfer of tubes from station to station the processing time is greatly reduced and the chance of sample tube mix-up is virtually eliminated. Models currently available include SP/E-48 (48 samples), and the SE 72.

The SE-72 is a stand alone sample evaporator designed specifically to be used with the Hamilton Company Microlab® Star robotic system; customized for use with the Biochemical Diagnostics gravity flow columns. Inquire about customized configurations for your application.

## II. BLOCK HEATER SPECIFICATIONS

A. Power Requirements: 110V + 10% 5 Amps 50-60Hz

B. Physical:

Weight: 20 lbs. (including heating block)

Dimensions: Width - 17.6''

Depth - 10.5''

Height (w/o guide posts) - 4.00''

Height (w/guide posts) - 10''

C. 1. Temperature Accuracy:  $\pm 3\%$  after calibration

2. Repeatability:  $\pm 3\%$

3. The heater can be calibrated for optimum performance.

D. Temperature Range: Room temperature to 100° C

E. Heater Wattage: SP/E-48 – 360 watts SE-72 – 360 Watts

F. Fuse: 5 amp resettable circuit Breaker – 110v

G. Power Cord: Standard three prongs, grounding required, indoor use only.

# Hardware

**Sample  
Prep.**

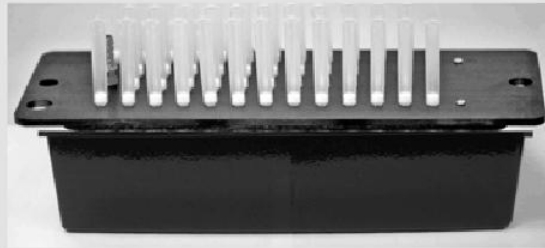

**Elute**

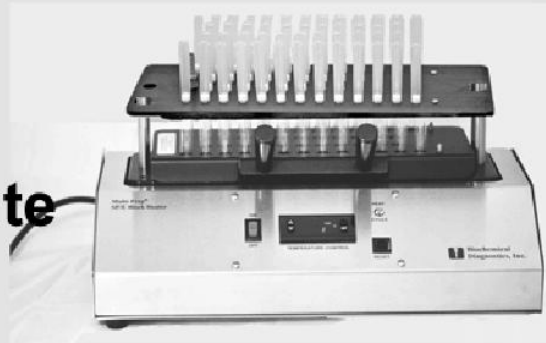

**Dry**



### III. OPERATING INSTRUCTIONS

**1** Columns are loaded into the column mounting plate, which is, in turn, positioned on the waste pan for sample processing according to the extraction method being followed. Plugs are provided to block unused column holes in the event that vacuum drying is required for the procedure being followed. The hose nipple on the waste pan is attached to a waste line that is normally open to allow liquids to flow into a waste container. If column drying is called for in the extraction procedure the stopcock is closed and the hose nipple on the column mounting plate is attached to a vacuum line. It is recommended that a liquid trap be incorporated in the vacuum line to protect the pump from contamination.

**2** The column mounting plate is moved to the transfer rack normally positioned on the SP/E Block Heater (A transfer rack support plate is available to position the transfer and rack column mounting plate if elution is to be performed outside of the SP/E heater). The SP/E-48 uses a threaded standoff that is screwed onto the column mounting plate to hold the standoffs in place. The two alignment rods on the heating block and four standoffs attached to the column mounting plate are used to position the column tips just inside the rim of the collection tubes. The standoffs are positioned onto locator pins set into the transfer rack. The standoffs and locator pins are keyed to each other to prevent reversal of the columns relative to the bar-coded or numbered collection tubes.

**3** The column mounting plate is removed from the SP/E Block Heater and is replaced with the evaporation manifold. The vertical position of the evaporation manifold is adjusted using the quick release support sleeves that slide up and down on each alignment rod when the split ring is pinched, and lock into position when it is released. A nitrogen or argon tank is hooked up to the manifold nipple and the gas flow is adjusted as needed. Plugs have been provided to seal drying tips that are not needed. The stainless steel evaporation tips are easily replaced by removing the four thumbscrews that hold the manifold cover in place. The temperature of the heating block is adjusted (ambient -90°C) as required by the extraction and/or derivatization method. The evaporation manifold should be stored upside down or on the support rack to prevent damage to the evaporation tips

## IV. INITIAL INSPECTION AND SETUP

This instrument has been carefully tested and inspected both electrically and mechanically before shipment. In addition, each unit undergoes a 16-hour burn-in. The instrument should be carefully inspected for damage from transit before discarding packing material. The shipping container must be retained for warranty repairs.

### ASSEMBLY INSTRUCTIONS:

**HEATING UNIT** - The upper heating block is lowered onto the lower heating block, which is keyed to accept the block in its proper position. Care must be taken to avoid damaging the temperature thermo-couple located on the right side of the lower heating block. This two-block configuration enables the quick interchange of heating blocks with different hole configurations.

**COLUMN MOUNTING PLATE** – The SP/E-48 requires the use of Universal Column Adaptors (UCA) to accommodate the 3 mL syringe barrel extraction column luer fittings. The amber column and syringe style column with built-in universal adaptor fit directly into the column mounting plate. A package of 50 UCA's is supplied with each SP/E-48 instrument. Each column hole is threaded to accept a UCA. The easiest way to screw the UCA into the column mounting plate is to fit a column into the luer fitting and turn the UCA clockwise until it is tightly seated in the plate. A slight clockwise turn of the column as it is being pulled upward will easily remove the column from UCA. An updated SP/E-28 column mounting plate is available with threaded holes. The earlier version uses a press fit UCA in an unthreaded hole. Either hole, threaded or unthreaded, will work with the 15 mL amber column without using a UCA. The rubber sealing gasket should be inspected before each use to insure that it is intact to provide a proper seal if vacuum is required.

## **V. INSTRUMENT TURN ON AND SETUP**

### **A. POWER SWITCH**

The power switch, when in the “on” position, applies power to the temperature control.

### **B. TEMPERATURE CONTROL**

Press the set button on the digital temperature control and the flashing digital temperature will be displayed. Press the up or down arrows for more than 2 seconds to change the temperature. Press set to exit the temperature set mode. The LED light remains on during the heating cycle and turns off when the set temperature is reached.

### **C. CALIBRATION**

*The SP/E instruments are factory calibrated and usually do not require further adjustment.*

Set the thermostat to the temperature at which you wish to operate the instrument. Insert a thermometer into the thermometer hole located forward of the guidepost on the left side of the heating block. Allow the temperature to rise until the heat cycle lamp goes off. If the temperature is not within 5% of the desired temperature the instrument may be calibrated as follows:

### **D. PARAMETER SETTINGS**

Press set button and hold for 6 seconds to enter the E1 parameter setup mode. Press again to step to the next parameter(s) E2, E3 E4, E5, P1, P2, P3, E1. Press the up or down buttons to modify the parameter values. If no button is pressed within 10 seconds, it will return to normal operations.

To lock the parameters, press the down button and hold for 10 seconds. LED will display “off”.

To unlock the parameters, press the down button and hold for 10 seconds. LED will display “on”.

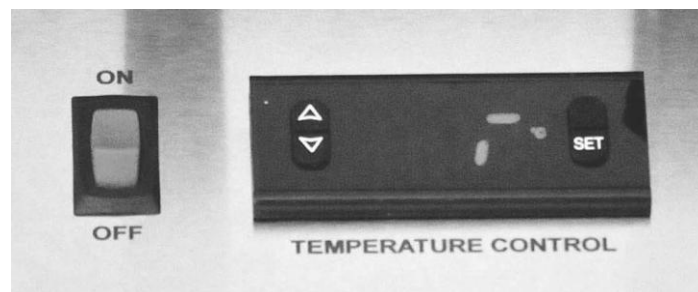

Parameter	Function	Set Range	Default
E1	Lower setpoint limit	0°C to set temp.	10°C
E2	Upper setpoint limit	Set temp. to 999°C	400°C
E3	Temp. hysteresis	1 to 99°C	10°C
E4	Comp. start delay time	0 to 10 mins.	2 min.
E5	Offset on cold-room temp.	-100°C to 100°C	0°C
P1	High temp. alarm value	P2 to 999°C	500°C
P2	Low temp. alarm value	0°C to P1	10°C
P3	Alarm delay time	0 to 90 mins.	60 mins.

### Parameter function details:

#### 1. Heating control:

- Heater starts heating when cold-room temperature is less than set temperature minus hysteresis.
- To prevent the heater from starting continuously, the heater cannot start until it reaches the E4 delay time.

#### 2. Alarm mode:

- When the cold-room temperature is  $\geq$  the highest alarm temperature (P1), or cold-room temperature is  $\leq$  the lowest alarm temperature (P2), and the time duration exceeds the alarm delay time (P3), it enters the alarm mode.
- When the cold-room temperature is  $\leq$  the highest alarm temperature (P1 minus 2°C) and  $\geq$  the lowest alarm temperature (P2) plus 2°C, it stops the alarm mode, the buzzer stops, the alarm LED turns off, and the alarm relay is disconnected.
- In the alarm mode, the instrument stops heating, the buzzer sounds, the alarm LED flashes, and the alarm relay is connected. Pressing any key will turn off the buzzer and stop the LED from flashing.

#### 3. Abnormal temperatures:

- When the temperature sensor is short circuited and exceeds 999°C “HH” is displayed. When the temperature drops below 0°C “LL” is displayed.

## POWER RESET

In the event that a power surge trips the 5 amp resettable circuit breaker, pushing the reset button located beneath the heat cycle lamp should restore power.

If this does not work it may indicate a more serious problem, in which case, please contact technical services at Biochemical Diagnostics, Inc.

## VI. MAINTENANCE

*The following work must be performed by an individual qualified to do electrical repairs.*

### REPLACEMENT OF SILICONE HEATING ELEMENT:

In the unlikely event that the silicone heating element needs to be replaced the following steps are necessary:

- A. Unplug the instrument power cord and allow the heating block to cool.
- B. Carefully remove the upper heating block taking care not to damage the temperature sensor which is located on the lower heating block.
- C. Remove the six screws holding the lower heating block in place on its base.
- D. Lift the lower heating block out of the unit taking care not to damage the temperature sensor.
- G. The silicone heating pad is now visible, located on the heating block base. Note its position to insure that the replacement pad is placed in the exact same location.
- H. Disconnect the two lead wires from the heating pad using the quick disconnect fittings.
- I. Remove the old heating pad.
- J. Peel the protective paper off the adhesive side of the new heating pad and press the pad (adhesive side down) onto the position of the old pad.
- K. Reconnect the lead wires and reattach the unit.

**Note:** Do not turn on the POWER until the heating blocks are in place. ***The heating pad will be damaged if it is not in contact with a heat sink when power is applied.***

### REPLACEMENT OF THE TEMPERATURE SENSOR CONTROL UNIT:

The temperature sensor control unit is located in on front control panel.

- A. Unplug the SP/E Block Heater power cord. Remove the upper heating block.
- B. Remove the protective housing and disconnect the wires from the unit.  
***Although a wiring diagram has been provided it is wise to mark the wires for easier replacement.***
- C. Remove the two screws holding the sensor control unit in place. Remove the leads from the thermocouple probe.
- D. Reverse the process to install the new Temperature sensor control unit.

### CLEANING THE EVAPORATION MANIFOLD DRYING TUBES

After placing the evaporation manifold in a fume hood they may be washed with methanol by washing the Teflon coated tubes individually as needed, or by dipping the evaporation manifold tubes into a bath of methanol, or using an aerosol sprayer to wash them.

## REPLACING THE TEFLON COATED STAINLESS STEEL EVAPORATION TUBES

Remove the evaporation cover and remove the plastic tubes after unscrewing the plastic nut and “O” ring. The new stainless steel tips are placed in their mounting holes with an “O” ring (provided) on the upper side of the aluminum plate. The nylon nut is threaded into place and hand tightened. Over tightening will cause the “O” ring to bulge out from beneath the nut.

## VII. PRECAUTIONS

***The Multi-Prep SP/E Workstation should be operated in a fume hood or Laboratory room designed for efficient fume removal.***

Prolonged contact of the workstation housing to strong solvents can soften the paint. To prevent softening, solvent spill should be blot dried as soon as possible.

## VIII. WARRANTY

Biochemical Diagnostics, Inc. warrants that the instrument has been tested by quality control to insure optimum operating performance and repeatability of results. We further warrant that this instrument is free from defects in material and workmanship. Should defects in materials or workmanship develop within 12 months from delivery of the product, we will service or repair the equipment without charge to the customer.

If we determine that misuse, abnormal operating conditions, or repair work by unauthorized personnel has caused a fault during the warranty period, repairs by Biochemical Diagnostics or an authorized service center will be billed according to the severity of the damage.

We reserve the right to perform warranty service either, on-site, in our own repair facility, or at an authorized repair center. Repair work and replacement of parts under the above warranties is F.O.B. factory or service branch.



**Biochemical  
Diagnostics, Inc.**

### CONTACT INFORMATION

**Biochemical Diagnostics, Inc.**

180 Heartland Blvd

Edgewood, NY 11717

Phone: 1-800-223-4835 -or- 631-595-9200

Fax: 631-595-9204

support@biochemicaldiagnostics.com

**BCD West:** Phone: 1-800-223-8803

bcdw@esedona.net

# IX. WIRING DIAGRAM

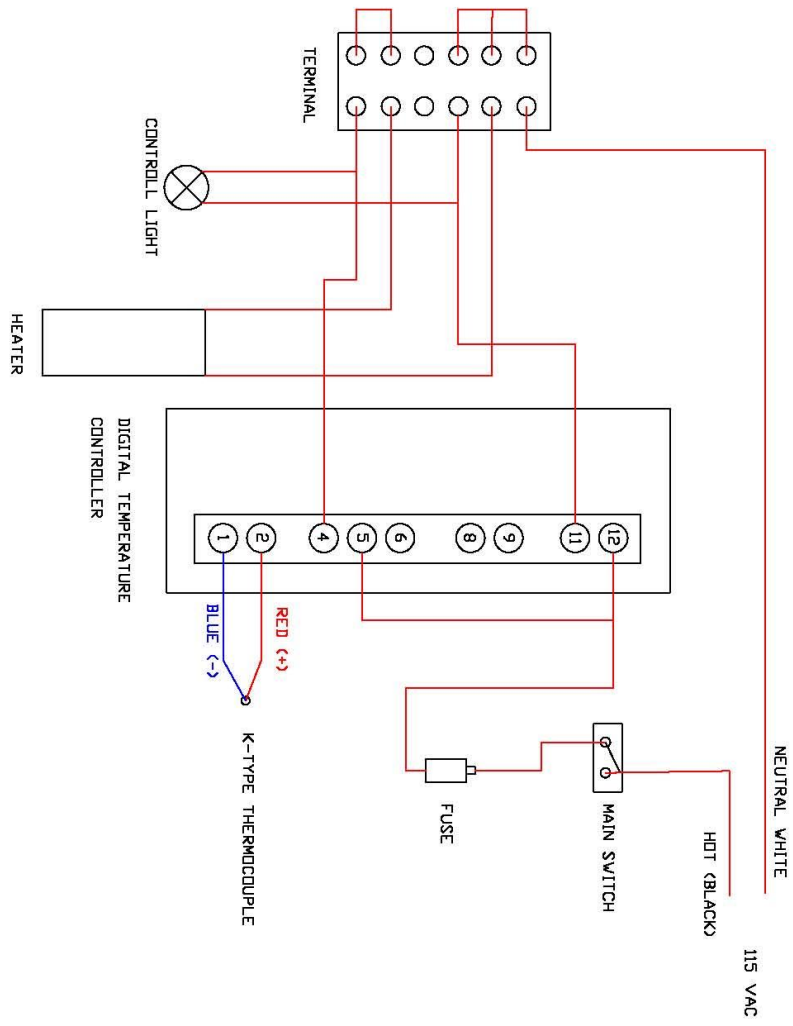

CIRCUIT DIAGRAM